

γ-CHAIN - LED
ATEX
4x150W - 7M



Antiexplosion
version



PHOS

γ-CHAIN-LED

4x150W LED - 7M

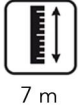

7 m



330Kg



340°



power

- ATEX lighting tower for explosive areas
- Multi-directionally adjustable and tiltable floodlights
- 5 sections hydraulic vertical tower 7m, 340° rotatable
- Manual lifting system by winch complete with auto-braking system
- Galvanized metalworks
- 80 µm powder coating
- Very compact dimensions for easy handling & transportability, up to 32 units per truck
- Light weight for improved manoeuvrability
- Central lifting eye, forklift pockets for effective handling
- Armored cable c/w plug to light up the unit
- Certified wind stability up to 110 km/h
- 4 extendable & height adjustable stabilizers
- On board levels for guidance during stabilization
- Patented mast emergency brake which prevents the falling of the mast in case of cable failure



**Antiexplosion
version**

PATENTED
The first lighting tower in the market that has a patented mast emergency brake system to improve safety of the operators on site (Registration number: 102017000044431)

APPLICATIONS



Special events



Rural & hard to reach areas



Emergency response



Construction & work sites



Gas, oil & mining operations



Military applications



Illuminated area
2400 sqm



very compact dimensions for easy handling & transportability up to 32 units per truck

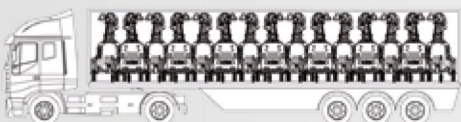

**32
Units Per Truck**

You can place 32 units on a single vehicle thanks to one of the compactest footprints on the market.



KEY BENEFITS

- *No fuel cost*
- ✓ *No carbon emission*
- ✓ *No maintenance*
- ✓ *No noise emissions*
- ✓ *32 units per truck*

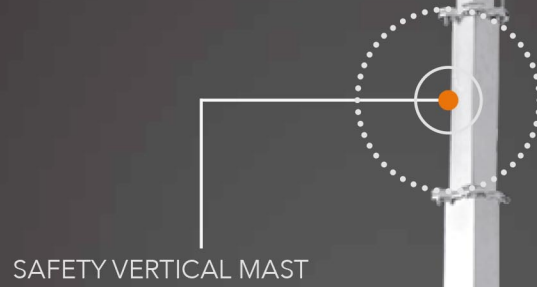
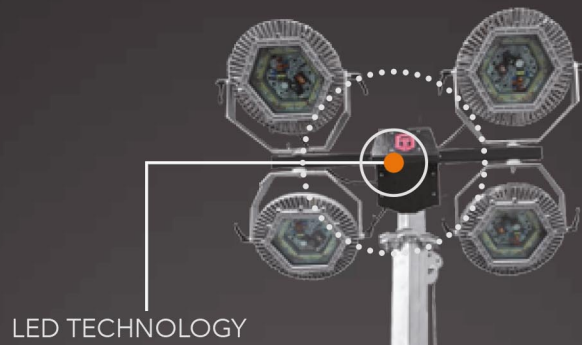

CENTRAL LIFTING EYE

GALVANIZED BODY
DURABLE ANTI-CORROSION
PROTECTION

4 ADJUSTABLE
STABILIZERS

DOUBLE SIZE FORK
LIFT POCKET

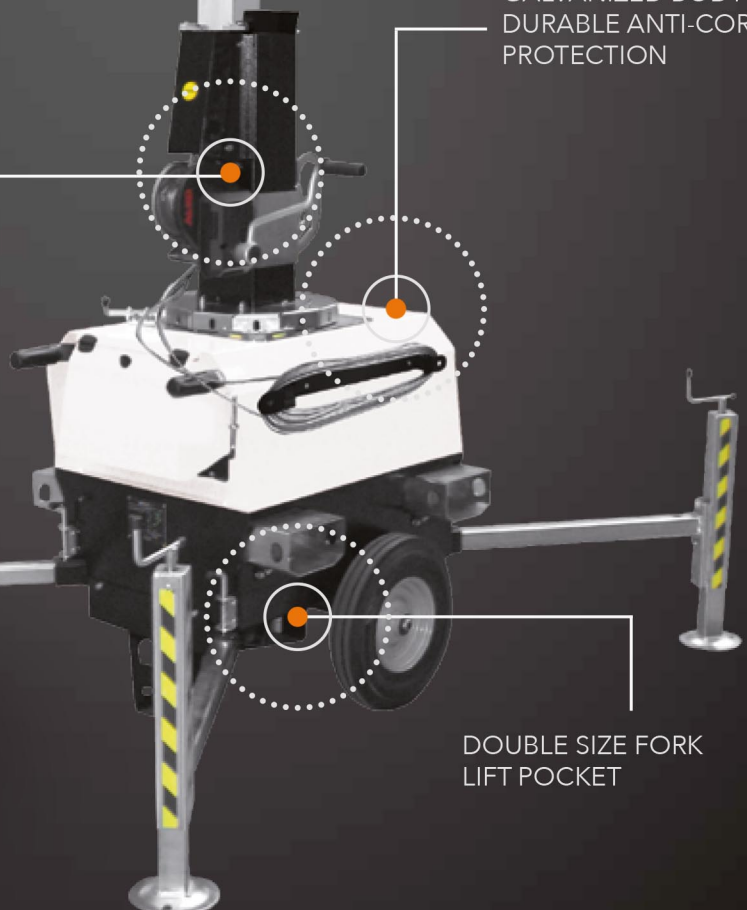
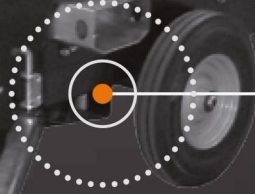
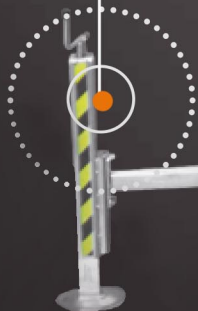

technical data

Dimensions & weight		Input & output	
Dimensions min. (mm)	1200x850x2100	Inlet plug	16 - 230V
Dimensions max. (mm)	1850x1450x7000	Tower lifting method	
Total weight	330 Kg	Manual	
Features		Trailer type	
Rotation	340°	Hand trolley	
Floodlights	ATEX 4x150W		
Lamps	LED		

Standard load delivery

32 sets

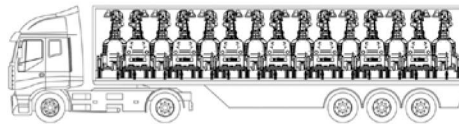

Units Per Truck

Illuminated area (5 lux min.)

2400 sqm

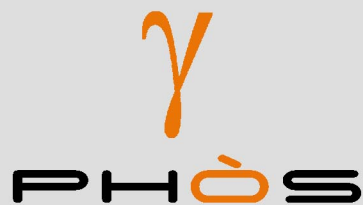
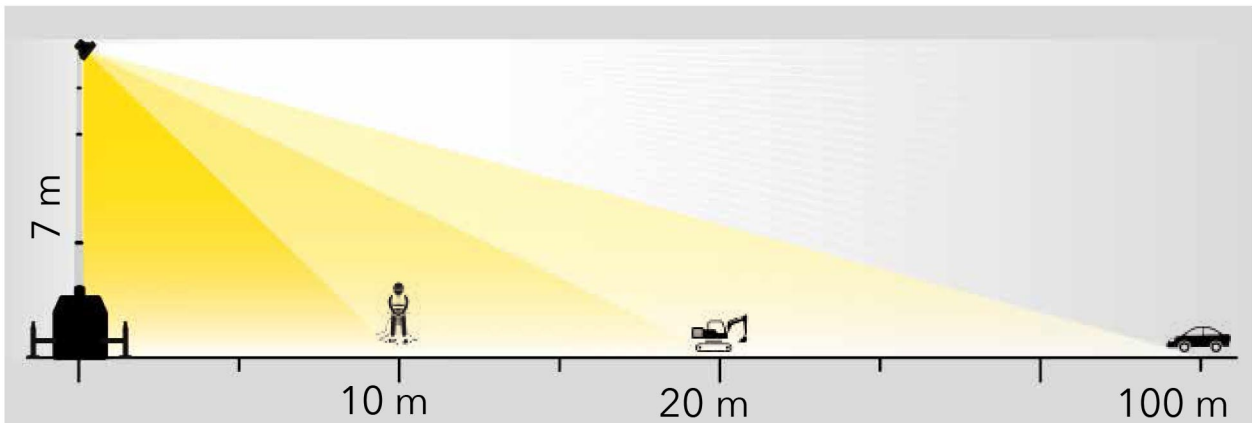

Diesel - Hybrid - Electric - Solar - Portable

AMOG srl | I-80031 Brusciano (NA) | Tel. +39 081 658 8361 | sales@davinogroup.biz

davinomixer.com